

SE 2500/S

MARINE VHF RADIO

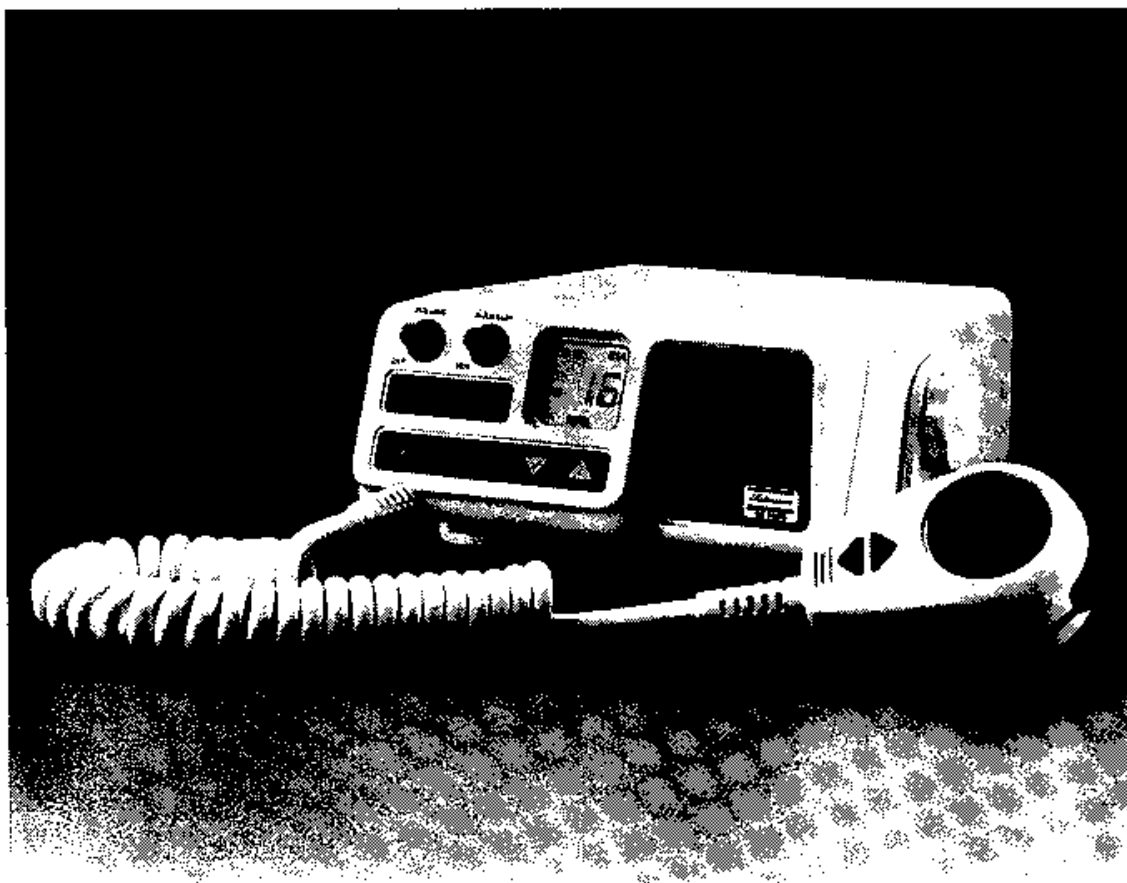

OWNER'S HANDBOOK

Shakespeare[®]

TABLE OF CONTENTS

1.0	Introduction.....	1	3.2.3	Setting Squelch.....	14
1.1	Purpose.....	1	3.2.4	Channel Selection.....	14
1.2	Equipment Description.....	2	3.2.5	USA/International Channel Select.....	15
1.3	Brief Operating Instructions.....	2	3.2.6	Voice Transmitting.....	15
1.4	Technical Specifications.....	4	3.2.7	High/Low Transmit Power....	16
1.5	Supplied Parts List.....	5	3.2.8	Transmitter 3 Minute Time Out.....	16
1.6	Optional Accessories.....	5	3.2.9	Weather Channels Access....	16
1.7	License Requirements.....	5	3.2.10	Channel 16 Priority.....	16
1.7.1	License Application.....	6	3.2.11	Channel 13/67 High Power Override.....	17
1.7.2	Operator's License.....	6	3.2.12	Dual Watch.....	17
2.0	Installation.....	7	3.2.13	External Speaker.....	17
2.1	Unpacking And Inspection....	7	3.3	Methods Of Operation.....	17
2.2	Mounting Preparation.....	7	4.0	Appendix.....	18
2.3	Mounting Location Selection.....	7	Appendix A.....	18	
2.4	Front Panel Reversal.....	8		USA VHF Marine Channel Assignments	
2.5	Unit Mechanical Installation..	9	Appendix B.....	19	
2.6	Electrical Connections.....	9		VHF Marine Weather Channel Assignments	
2.6.1	Power Hookup.....	10	Appendix C.....	19	
2.6.2	Antenna Connection.....	10		International VHF Marine Channel Assignments	
2.6.3	Coax Connector Assembly....	11	Appendix D.....	20	
2.6.4	External Speaker Connection.....	12		Canadian VHF Marine Channel Assignments	
3.0	Operation.....	13	Appendix E.....	22	
3.1	Controls And Display.....	13		Phonetic Alphabet And Glossary	
3.2	Operating Procedures.....	14	Appendix F.....	23	
3.2.1	Power and Volume Control.....	14		Schematics	
3.2.2	Display Backlighting.....	14			

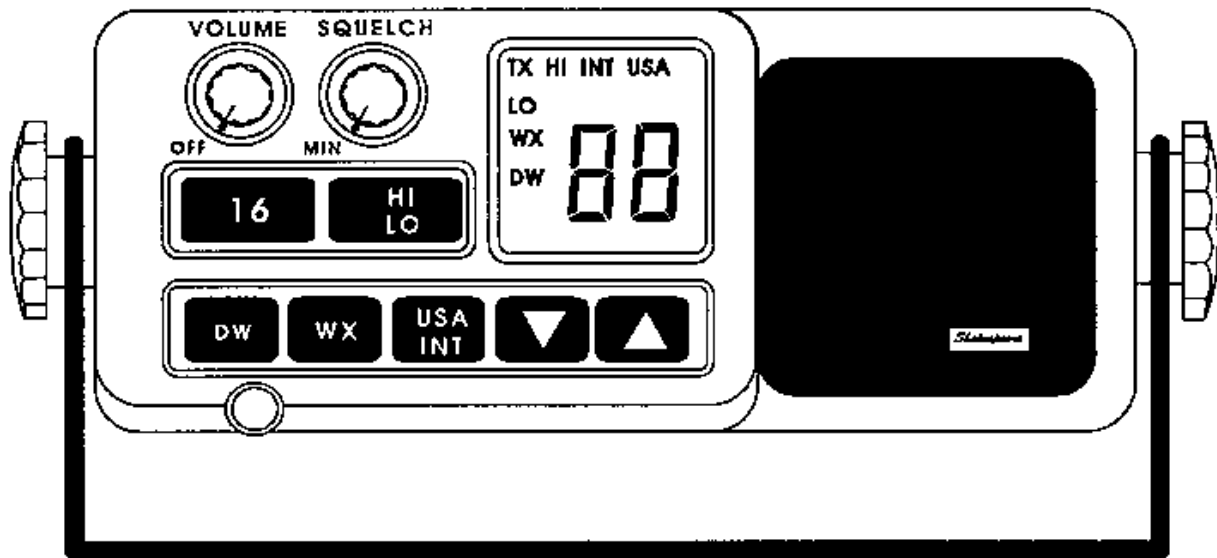

Figure 1-1 Shakespeare SE 2500 Marine VHF Radio.

1.0 INTRODUCTION

Welcome and congratulations on your purchase of the Shakespeare SE 2500 Marine VHF radio. You have purchased a high technology piece of marine electronics, fully backed by the Shakespeare name. The Shakespeare SE 2500 Marine VHF radio incorporates modern styling and functionality, making the Shakespeare SE 2500 not only easy, but pleasing to operate.

The frequency synthesized transceiver provides access to ALL usable U.S. and International Channels. Ten weather channels are also available through easy front panel key presses making the SE 2500 the best value in marine VHF radio.

The key to obtaining the most use and pleasure from your new VHF radio, is reading the owner's manual. This manual teaches you proper transceiver procedures and care to ensure many years of satisfying use. It is especially important to cover the areas of this manual pertaining to "License Requirements" established by the Federal Communications Commission.

1.1 Purpose

The Shakespeare SE 2500 Owner's Manual is designed to answer your questions about the installation and operation of your radio. It is important to read through each section before attempting to install or operate your radio. A "Brief Operating" section assures you are on the air quickly and properly. Many new user pitfalls can be avoided by reading this manual.

1.2 Equipment Description

The Shakespeare SE 2500 Marine VHF radio is a digitally synthesized transceiver constructed of only the highest grade materials. All electronic components are solid state providing the most efficient use of electrical power. The Shakespeare 2500 VHF radio offers two output settings, 1 watt and 25 watts. The microprocessor control used in this radio offers features found only in far more expensive units. Features such as Dual Channel Watch, Priority Channel 16, and 10 Weather Channels are only some of the Shakespeare SE 2500's many extras.

1.3 Brief Operating Instructions

Use the following brief operation instructions to quickly refresh your memory when using the Shakespeare SE 2500 Marine VHF radio. Please remember that this section is not designed to replace a thorough study of the Owner's Manual.

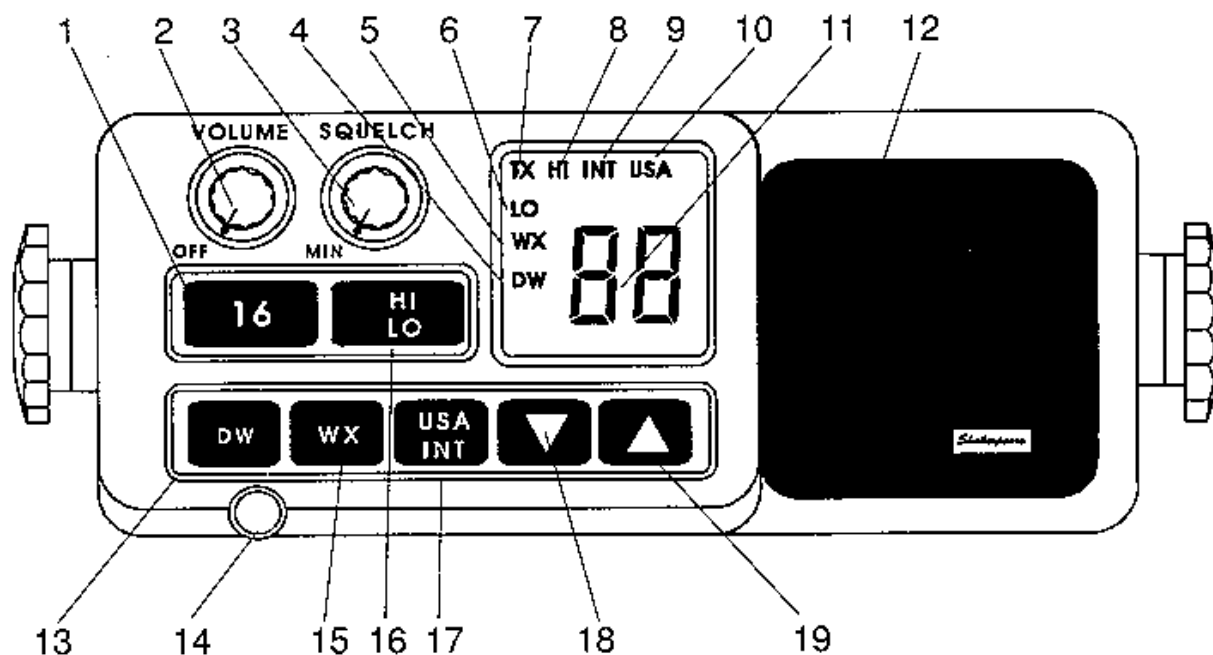

- | | |
|-----------------------------------|----------------------------------|
| 1-Channel 16 select key | 10-USA channel indicator |
| 2-Power and Volume control | 11-Active channel readout |
| 3-Squelch Control | 12-Speaker |
| 4-Dual Watch active indicator | 13-Dual Watch select key |
| 5-Weather Channel indicator | 14-Microphone cable |
| 6-Lo Power Output indicator | 15-Weather mode select key |
| 7-Transmit active indicator | 16-HI/LO transmit power key |
| 8-Hi Output power indicator | 17-USA/International channel key |
| 9-International channel indicator | 18-Down channel select key |
| | 19-Up channel select key |

1.2 Equipment Description

The Shakespeare SE 2500 Marine VHF radio is a digitally synthesized transceiver constructed of only the highest grade materials. All electronic components are solid state providing the most efficient use of electrical power. The Shakespeare 2500 VHF radio offers two output settings, 1 watt and 25 watts. The microprocessor control used in this radio offers features found only in far more expensive units. Features such as Dual Channel Watch, Priority Channel 16, and 10 Weather Channels are only some of the Shakespeare SE 2500's many extras.

1.3 Brief Operating Instructions

Use the following brief operation instructions to quickly refresh your memory when using the Shakespeare SE 2500 Marine VHF radio. Please remember that this section is not designed to replace a thorough study of the Owner's Manual.

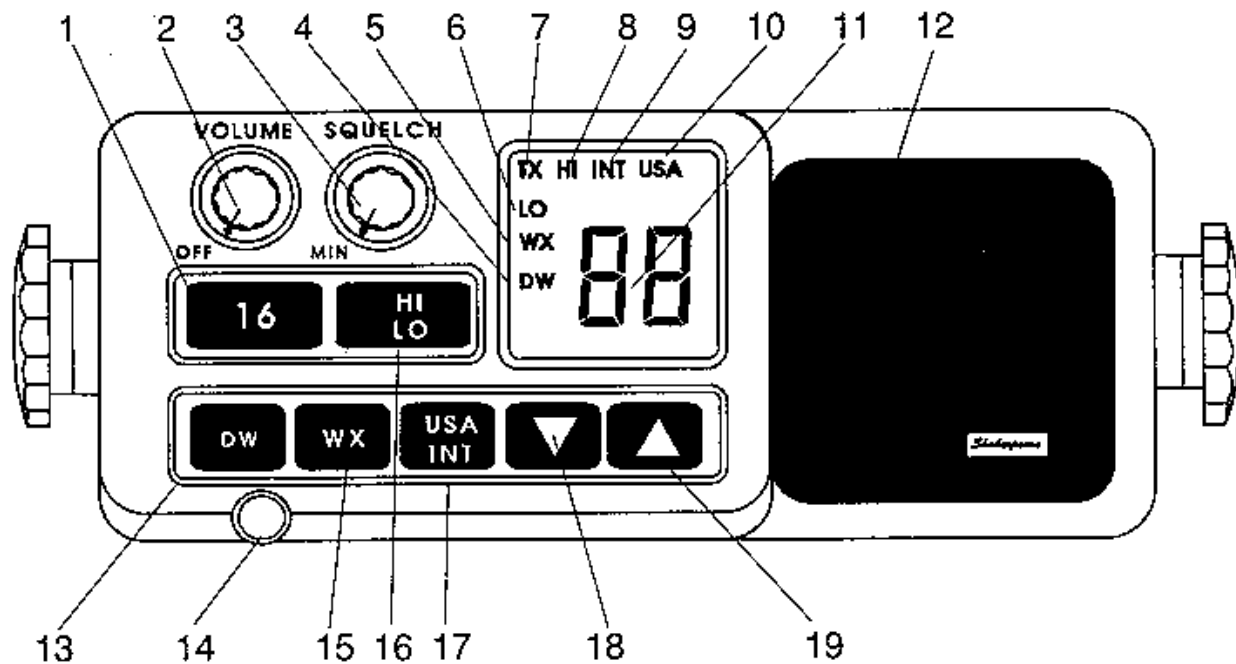

- | | |
|-----------------------------------|----------------------------------|
| 1-Channel 16 select key | 10-USA channel indicator |
| 2-Power and Volume control | 11-Active channel readout |
| 3-Squelch Control | 12-Speaker |
| 4-Dual Watch active indicator | 13-Dual Watch select key |
| 5-Weather Channel indicator | 14-Microphone cable |
| 6-Lo Power Output indicator | 15-Weather mode select key |
| 7-Transmit active indicator | 16-HI/LO transmit power key |
| 8-Hi Output power indicator | 17-USA/International channel key |
| 9-International channel indicator | 18-Down channel select key |
| | 19-Up channel select key |

BRIEF OPERATIONS TABLE

POWER ON	Turn Volume Control CLOCKWISE .
VOLUME	Adjust Volume Control to desired setting.
SQUELCH	Turn Squelch Control knob counterclockwise until noise is heard. Turn Squelch Control knob clockwise slowly, just until noise is no longer heard.
BACKLIGHT	The backlighting is on all the time.
USA/INT	This key changes the available channels to USA or International allocations. See Appendix A through D for complete channel listing and usage.
SELECTING CHANNELS	Pressing the UP/DOWN arrow keys on the front panel, or the front of the microphone, scrolls through the available channels. The displayed channel is the active channel.
EMERGENCY CALLING	Press 16 key for channel 16. This channel is used to call the Coast Guard and general vessel calling. Always switch to another channel to chat. To leave Emergency-Calling Channel 16 press DW , WX , or Channel Select UP/DOWN arrows keys.
TRANSMIT POWER	Press HI/LO to toggle between 1 and 25 watts.
TRANSMIT	Press and hold the PUSH-TO-TALK key on the top of the microphone to transmit.
WEATHER CHANNELS	Press WX to access the last selected weather channel. To change Weather Channels use the UP/DOWN arrow keys. To exit the weather channels press 16 or WX .
DUAL WATCH	Set Squelch, then select a channel other than Channel 16. Press the DW key. To stop, press 16 or WX .

NOTE

- 1 beep confirms a valid entry or selection.
- 3 beeps mean an invalid entry-PLEASE TRY AGAIN.

1.4 Technical Specifications

General

Physical Characteristics	Height: 2.5" Width: 6.0" Depth: 8.0" including heat sink Weight: 2.0 lbs.
Temperature Range	-20 Deg C to +50 Deg C
Power Requirements	13.8 VDC nominal, 5.5 A transmit, .2 A receive
Channels	124 total, 57 USA, 57 International and 10 Weather

Transmitter

Output Power	25 Watt/1 Watt
Output Impedance	50 Ohms
Modulation	FM, 5 KHz max deviation
Frequency Stability	+/- .0005% (5ppm)
Spurious Emissions	2.5 uW (-56 db) @ 1 Watt Tx 25 uW (-70 db) @ 25 Watt Tx
Hum and Noise	-40 db
Audio response	Less than 10% distortion at 3khz deviation. 6db/octave pre-emphasis, Audio low pass filter included.

Receiver

Sensitivity	.25uV or less for 12db SINAD .50uV or less for 20db SINAD
Selectivity	-6db at 7.5 KHz -65db at 25 KHz
Spurious Response Attenuation	70db min.
Intermodulation Spurious Response Attenuation	70db min.
Audio Output Power	3 Watts @ 8 Ohms 6 Watts @ 4 Ohms External
Audio Distortion	10% @ 3 Watts into 8 Ohms
Audio Response	+1/-3 db matching a 6db/octave de-emphasis from 300-3000Hz
Squelch Sensitivity	Threshold: .30 uV Max, Full Squelch: .80 uV

Specifications are subject to change without notice and are nominal unless otherwise indicated.

1.5 Supplied Parts

- SE 2500 Radio Transceiver
- Plastic Mike Clip with screws
- Special Waterproof Mike
- Spare 7 Amp fuse
- Mounting Knobs
- Mounting Bracket
- Power Cable Assembly with fuse holder
- Owner's Manual
- Waterproof Brief Instruction Card
- FCC Application-506
- FCC Restricted Operator's Permit-753
- Warranty Card

1.6 Optional Accessories

- Flush Mount Installation Kit
- Reverse Panel Gasket

Be sure to consult your marine electronics dealer for a Shakespeare antenna that best suits your particular installation. Shakespeare has been building a reputation for uncompromising quality in marine communications for more than 35 years. A reputation that our US Navy and Coast Guard have come to count on. So whether you selected your Shakespeare radio for peace of mind or for fun, we recommend you consult your Shakespeare marine electronics dealer for the wide variety of marine antennas and accessories available. He can help you select the system combination that best fits your boat and needs.

1.7 License Requirements

Pleasure boats (U.S. vessels), equipped with a marine radio, must have a Ship Station License. Other vessels (including compulsory equipped vessels) may require a Ship Radio Station License and a Commercial Radio Operator's License to operate the radio station. If the ship is not a U.S. vessel, contact the local authorities to determine licensing requirements.

When purchasing a new boat, a new station license must be applied for as the "Ship Station License" is not transferable. Therefore, upon the sale of your boat, the FCC requires that you submit your old license for cancellation.

A change in mailing address requires notification to be filed with the FCC. This notification is mailed to:

Federal Communications Commission
P. O. Box 1040
Gettysburg, PA 17326

1.7.1 License Application

The Ship Radio Station License is obtained by filling out and submitting Form 506 with \$35 to the FCC. **DO NOT SEND CASH.** To operate the radio while waiting for the license to be returned from the FCC, fill out and keep the bottom part of Form 506. This "Temporary Permit" is good for 90 days from the date the Form 506 is mailed to the FCC. Your Ship Station License is valid for a period of 5 years. The call sign for your station will be issued on the license and the temporary permit has instructions for assigning the vessel's temporary call sign.

If the ship's radio station is to be operated in other countries, contact the local authorities for their licensing requirements.

Mail Station License Application form to:

Federal Communications Commission
Marine Ship Service
P. O. Box 358275
Pittsburgh, PA 15251-5275

1.7.2 Operator's License

A Commercial Radio Operator's License is generally not required to operate a ship's radio station aboard a pleasure boat. A Restricted Radiotelephone Operator Permit is not required for domestic operation of a marine VHF radio for U.S. pleasure boats as long as you do not dock in any foreign ports. If you are going to dock in a foreign port or plan to leave a foreign port to dock in U.S. ports, it will be necessary to obtain the Restricted Permit. To do this fill out and mail to the FCC a Form 753 along with a \$35 fee in the form of a single check or money order payable to the FCC. **DO NOT SEND CASH.** For further license information call the FCC at 717-337-1212.

2.0 INSTALLATION

Before using the Shakespeare SE 2500 Marine VHF radio, please study the following section. Failure to adhere to these installation and operating considerations can damage or significantly degrade the performance of your VHF radio.

2.1 Unpacking And Inspection

The Shakespeare SE 2500 Marine VHF radio comes to you 100% inspected. When unpacking, check the parts shipped with the unit against the supplied parts list. If there is a discrepancy, notify your selling agent or Shakespeare Customer Service. (1-803-276-5504)

If the radio was damaged during shipment, save ALL packing material to make it easier to file a claim with the carrier. All damage claims from shipment must be filed with the freight carrier used to ship the radio to you.

2.2 Mounting Preparation

Before actually mounting your new SE 2500 Marine VHF radio, take a little time to read over the installation instructions. You will find there are many things to take into consideration before drilling that first hole. Planning every aspect of the installation first, will save time and aggravation. It will also save money by cutting down potential errors that require repair to correct.

Before mounting begins you will need to purchase a marine VHF radio antenna. Shakespeare markets a full line of high quality marine VHF radio antennas to fit every installation. The dealer you purchased this radio from will be able to help you choose the antenna style best suited to your type of boating.

2.3 Mounting Location Selection

The following is a list of items that need advanced planning before selection of the mounting location.

1. Find where the vessel's +12 volt supply and ground are located and what it will take to get the radio power cable assembly to it .
2. Where can the antenna be mounted and what must be done to route the antenna cable to the radio?

NOTE

Keep the antenna at least 3 feet away from the radio and as high as possible for best performance.

3. Where is the best place to mount the radio itself? Keep in mind that the radio may be table top mounted, hang mounted overhead, bulkhead mounted vertically, under counter mounted and flush mounted using the optional Flush Mount Kit.
4. When deciding on a mounting location, visibility of the front panel, access to the front panel controls, access to the mounting knobs, room for rear cable connections and access to rear cable connections must be addressed and planned.

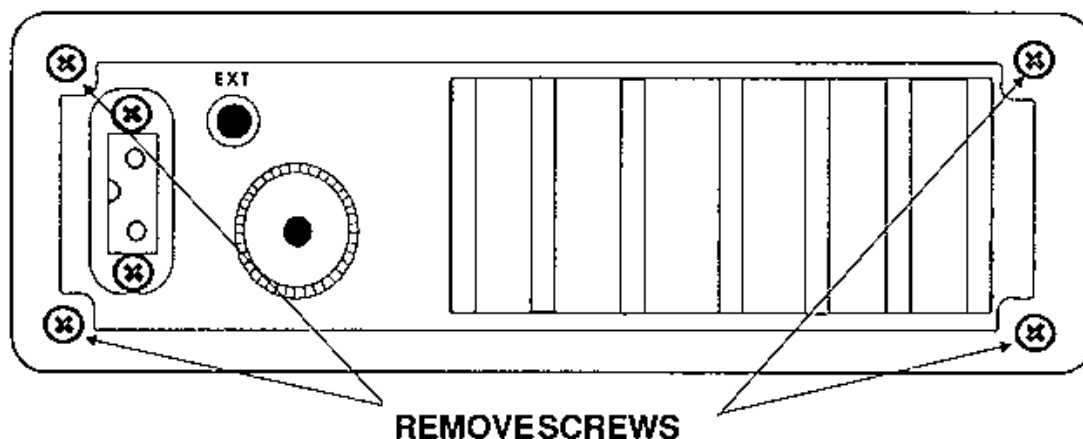

Figure 2-1 Screws to remove for front panel reversal.

2.4 Front Panel Reversal

For overhead and bulkhead installations follow these instructions to reverse the front panel. Do this before mounting the radio.

1. Disconnect all connections from the back of the radio. Then remove the four screws on the back of the unit securing the case to the chassis.
2. Slide the case off of the radio and replace the original front panel gasket with the reverse front panel gasket.
3. Rotate the case 180 degrees.
4. Tilt the display forward 40 degrees.
5. Slide the case back on the chassis. Do not pinch any wiring or cabling.
6. Seat the case on the front panel and re-install the screws on the back of the radio. Do not over torque the screws.
7. Mount the trunnion bracket on the top of the radio. Figure 2-2 shows the "before" and "after" results.

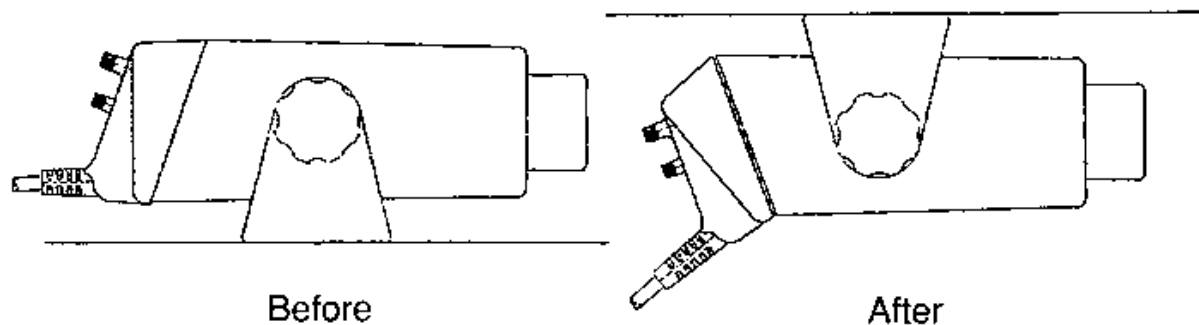

Figure 2-2. Front Panel Reversal procedure.

2.5 Unit Mechanical Installation

Once a mounting location has been chosen, hold the mounting bracket at the place where the unit is to be mounted. Use the mounting bracket as a template to mark the places to drill holes for the mounting screws.

To mount the bracket to wood use stainless steel wood screws. If the unit is to be mounted on fiberglass, use stainless steel nuts and through bolts as the vibrations found on most pleasure boats will loosen self tapping screws mounted directly into fiberglass.

When the mounting bracket is secured, attach the SE 2500 to the bracket using the mounting knobs supplied with the unit. For overhead and bulkhead installations reverse the front panel.

2.6 Electrical Connections

The back panel of the SE 2500 comes with the following standard connections.

1. Electrical Power (+12 volts)
2. Antenna Connector (for PL-259 type connections)
3. External speaker (1/8 " phono plug receptacle)

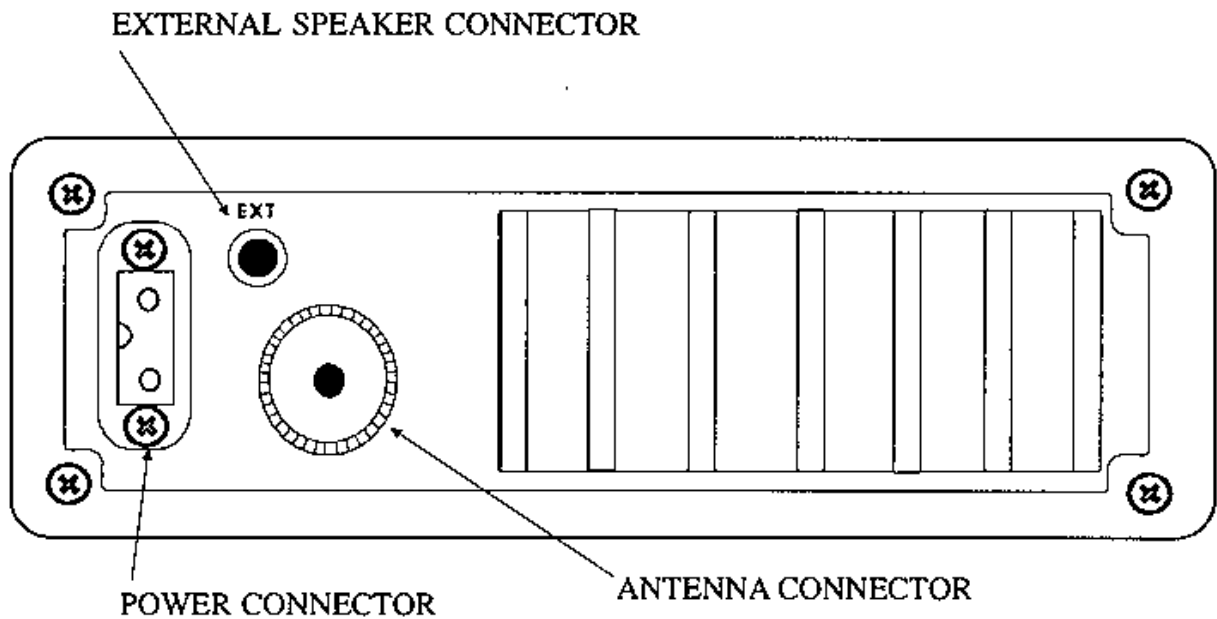

Figure 2-3 Rear panel electrical connections.

2.6.1 Power Hookup

The SE 2500 is supplied with a power cable assembly. The free end of the cable is connected to the battery side of the vessel's +12 volt power buss. The cable is equipped with a 7 Amp in-line fuse holder for over-current protection. The **Red (+)** side is connected to a +12 volt buss. The **Black (-)** side of the cable is connected to the Negative or Ground side of the ship's power. After the power cable is connected to the ship's power, plug the connector end into the back of the radio.

NOTE

Use at least 12 gauge wire to carry the transmit 5.5 Amp current. This wire size is appropriate for up to 20 feet of cable length.

When powering up the SE 2500, if no display appears once the power is turned on, check the power cable hookup polarity if the in-line fuse is blown. Remember to replace the fuse with one of the same 7 Amp rating. Using a fuse with a higher rating can result in permanent damage to the radio.

2.6.2 Antenna Connection

DO NOT attempt to operate the SE 2500 without the antenna connected, to do so can result in severe damage to the transmitter portion of the radio and void the warranty.

Plug the antenna cable PL-259 connector into the antenna connector on the rear panel of the SE 2500 Marine VHF radio. **ALWAYS**, screw down the outer coupling ring of the connector to ensure a solid connection.

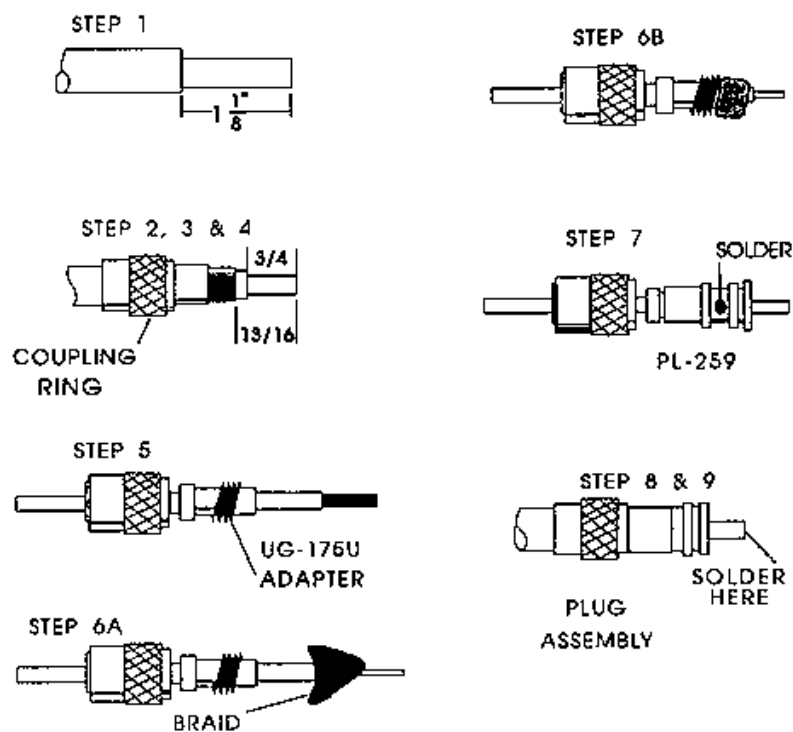

Figure 2-4. Coax Connector Assembly.

2.6.3 Coax Connector Assembly

1. Trim back outer jacket of coax back 1-1/8".
2. Trim back the braided shield, 13/16"
3. Trim back center insulation 3/4"
4. Slip coupling ring over cable.
5. Insert cable through the middle of the UG-175U adapter.
6. Fold the braided shield back over the end of the UG-175U adapter. Be sure there are no shield wires touching the center conductor.
7. Screw the UG-175U adapter into the PL-259 connector while feeding the end of the center conductor of the cable through the hole at the end of the plug.
8. Solder the center conductor of the coax to the center of the PL-259 connector. Trim center conductor. Solder braided shield to the PL-259 connector via the small holes.
9. Screw coupling ring onto the PL-259 connector.

NOTE

If you are not sure about this procedure, have a qualified marine radio service technician assist you.

2.6.4 External Speaker Connection

In high noise areas it is often desirable to install a more powerful external speaker. Purchasing and mounting of the speaker is left to the discretion of the owner as there is a great variety of external speakers available, but be sure a model capable of 8 Watts is purchased. We recommend a watertight model for long service.

Obtain a 1/8" phono plug from your local electronics supply house. To connect the external speaker, solder the two leads from the speaker to the connections on a 1/8" phono plug. Next, plug the phono plug into the external speaker connector on the back of the radio.

After installation is complete, use the external speaker as you would the internal speaker.

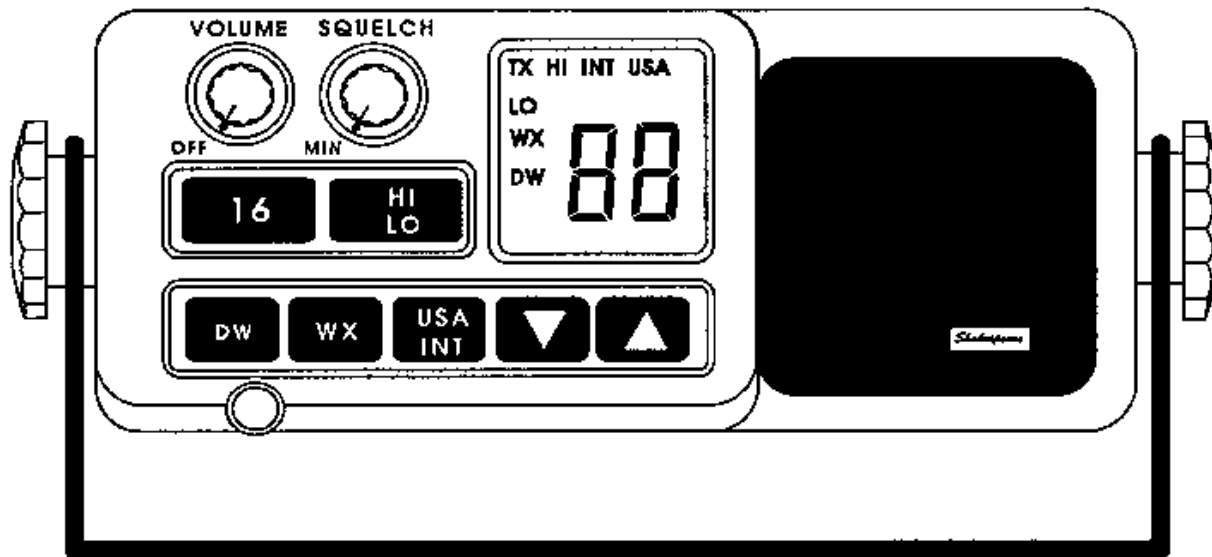

Figure 3-1. SE 2500 Front Control Panel.

3.0 OPERATION

The Shakespeare 2500 Marine VHF radio was designed for the tough marine environment, with special attention paid to ease of operation. The following section helps you realize the maximum benefit of your purchase. The SE 2500 marine VHF radio is not only a communications convenience, but a valuable tool in life threatening situations. This life saving potential makes thorough study of this Owner's manual extremely important.

3.1 Controls And Display

All controls and displayed information can be found on the front panel of the SE 2500. Two knobs on the front panel control power ON/speaker volume and squelch adjustment. The red backlit LCD display shows selected channel, transmit power setting, dual watch mode and transmit mode. The tactile keypad, with individual switches behind the overlay, controls selection of receive and transmit channels, transmit power level, dual channel watch, weather channels, USA or International channels and instant channel 16 priority select. A single beep of the radio indicates a valid keyboard entry. Three beeps means an invalid entry- PLEASE TRY AGAIN.

3.2 Operating Procedures

3.2.1 Power and Volume Control

To apply power to the SE 2500 VHF radio, turn the Volume Control knob (front left control knob), clockwise. A “click” is heard and felt. At this point the display shows numbers and annunciators. The SE 2500 remembers the last channel and mode you



were using before “TURN OFF” and goes to this same configuration at “TURN ON”.

The next thing to do is adjust the Squelch (see below). To do this, turn the Squelch Control knob counterclockwise until static is heard in the speaker. Now, the volume of the speaker can be adjusted to a reasonable level by the Volume Control. Make this adjustment by turning the volume control back and forth until you are comfortable with the background Noise level.

3.2.2 Display Backlighting

The backlighting of the display comes on when the SE 2500 is powered up and stays on for the entire time period that the radio is on. There is no brightness adjustment.

3.2.3 Setting Squelch

To adjust the squelch setting, start by turning the Squelch Control knob (front right control knob), all the way counterclockwise. Rotate the Volume Control knob until the static noise heard in the radio speaker is at a comfortable level. Next, when no radio transmissions are being heard, turn the Squelch control knob clockwise just to the point that the static noise is no longer heard. This quiets the static between received radio transmissions and still allows the incoming messages to be heard.



The level of squelch adjustment needed to quiet the radio static noise is dependent on the background static intensity. Keep in mind that the squelch may need to be adjusted when listening to a different channel.

3.2.4 Channel Selection

Channel selection for the normal transmit/receive channels is handled by two separate sets of controls. One set of channel selection arrow keys is found on the front panel directly below the LCD readout. The

CHANNEL SELECT KEYS



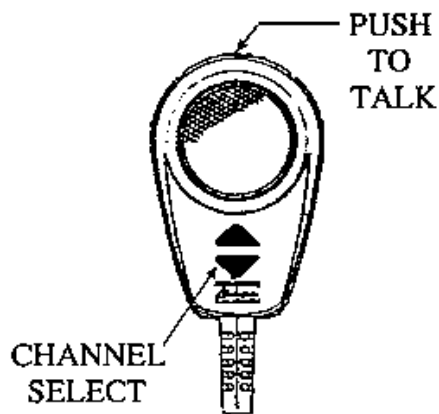

other set is found on the front of the microphone. The current channel selection is viewed in the LCD display area.

To change channels using either set of arrows, simply press **UP/DOWN** arrow keys. Observe the changing channels in the LCD display area. From your present channel, pressing **UP** arrow key will increase the channel numbers. In the same respect, from your present channel, pressing the **DOWN** arrow key decreases the channel numbers. If the

highest or lowest channel available is reached and the pressing of the arrow key is continued, the channel numbers will cycle around to the top or bottom of the list and continue changing. Holding the **UP** or **DOWN** changes the channel at a rapid rate. Practice several times to become accustomed to this. Some channels have no TX function (ie. 15, 75, 76 guard channels). Please study the channel allocation list in the Appendix to become familiar with the proper and customary usage.

3.2.5 USA/International Channel Select

The SE 2500 is programmed to access both United States and International channels. Which set of channels you use is determined by the area of operation. Normally in U.S. coastal areas and ports, the USA channels are selected.

To toggle between USA and International channels, press the **USA/INT** key. The channel type selected is indicated in the display.

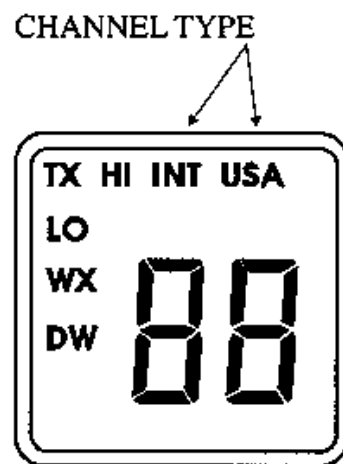

3.2.6 Voice Transmitting

Until you have memorized the proper usage of each channel, refer to the Assignment Appendices before attempting to make a voice transmission. There you will find a listing of the channels and their usage.

Once the proper channel has been selected, locate the **Push-To-Talk** key on the top of the microphone. The **Push-To-Talk** key will be referred to from here on out as the **PTT** key. To transmit, press and hold **PTT** for the entire transmission. While **PTT** is held in, speak into the microphone slowly and clearly. When the transmission is complete, release the **PTT** key. While the **PTT** key is being held, "TX" appears in the LCD display window.

3.2.7 High/Low Transmit Power

POWER SELECT

The SE 2500 has two transmit power output levels, 1 Watt and 25 Watts. The low power level (1 Watt) is provided for situations where the two parties involved are close to each other. This reduces the congestion on the same channel in areas far away, allowing more individuals to use a channel at one given time.



To toggle the power output selection between "LO" and "HI" press the **HI/LO** key. The transmit power output level is displayed in the LCD display window.

3.2.8 Transmitter 5 Minute Time Out

In the event that the **PTT** key is held in for too long, the transmitter timer will disengage the transmit function after 5 minutes. The **PTT** must be lifted and pressed again to continue transmission. This is designed to prevent a channel from accidentally being tied up by a malfunctioning microphone or transmitter.

3.2.9 Weather Channels Access

The SE 2500 has the ability to monitor National and International weather service broadcast. This safety feature allows you to listen to weather reports at any time so changes can be made in your boating plans. This allows you to alter your planned course and to make shipboard preparations.

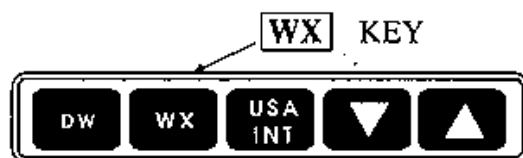

To change from standard marine VHF channels to the weather channel broadcast, press the **WX** key. "WX" appears in the LCD display indicating weather channel reception. The initial weather channel displayed, is the last one used. Use the channel change arrow keys on the microphone or the front panel to select a another weather channel.

To cancel weather channel access, press the **WX** or the **16** key.

3.2.10 Channel 16 Priority CH 16 PRIORITY KEY

As a convenience and safety feature, the SE 2500 marine VHF radio has a channel **16** priority key. Pressing this key from any mode or channel immediately changes the selected channel to channel 16 with the power output changed to "HI".



To leave Emergency-Calling Channel 16, press the channel selection keys.

3.2.11 Channel 13/67 High Power Override

Due to the special usage, FCC assigned channels 13 and 67 are restricted to 1 Watt under normal conditions. In some situations it is acceptable to override this output level and transmit on channels 13 and 67 at 25 Watts. To do this, press and hold the **[HI/LO]** key on the front panel of the radio for the duration of the transmission.

The LCD display shows "HI" in the display window while the **[HI/LO]** key is held in. Upon releasing the **[HI/LO]** key, transmit output power is dropped back to 1 Watt. When another marine VHF channel is selected, the **[HI/LO]** key toggles the transmit power setting between 1 and 25 watts, and does not have to be held in for "HI" power.

3.2.12 Dual Watch

The Dual Watch feature allows you to monitor channel 16 and ONE other channel. To make use of this feature the squelch must be properly set.

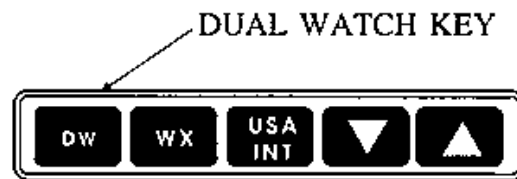

Once the squelch is set, select the "other" channel using the channel select arrow keys on the front panel or front of the microphone. Next, press the **[DW]** key. "DW" is annunciated in the LCD display. The channel display then changes between channel 16 and the "other" channel until a squelch break occurs. The channel displayed at the time of the squelch break is then held in the display for 4 seconds after the end of the squelch break.

Pushing the **[PTT]** key disables the Dual Watch mode at any time. Also, pressing the channel arrow keys, the channel **[16]** priority key, the **[WX]** key or the **[DW]** key turns the Dual Watch mode OFF. Any other key press produces 3 beeps and results in no change in current configuration.

3.2.13 External Speaker

When the external speaker is connected to the SE 2500, the speaker on the front panel is disabled automatically. The volume is adjusted in the same way as it is for the front panel speaker using the volume control knob.

3.3 Methods of Operation

The marine VHF radio channels are becoming ever increasingly crowded. This makes it very important and every users responsibility to help relieve channel congestion through use of professional radio techniques. The following the suggested rules will help everyone using marine VHF.

1. Before transmitting, listen to the channel for traffic already in progress. This will stop you from interfering with others using the channel ahead of you. Keep your transmissions as brief as possible but still make your message understood.
2. Give distress calls **PRIORITY**, unless you are in a position to help. Do not transmit but continue to listen.
3. If there is no response to your call, wait 2 minutes before trying again.
4. Calls on channel 16 should be less than 30 seconds in length. Once contact is established, switch to another channel that is more appropriate for your type of communication. Refer to the Appendices on channel assignment for the correct channels to use. Use professional terminology by referring to the Glossary and the phonetic alphabet found in Appendix E.

4.0 APPENDIX

APPENDIX A - USA VHF MARINE CHANNEL ASSIGNMENTS

CHANNEL		TRANSMIT	MODE	RECEIVE
01A	Port Operations	156.050	S	156.050
02A	Port Operations	156.100	S	156.100
03A	Port Operations	156.150	S	156.150
04A	Port Operations	156.200	S	156.200
05A	Port Operations	156.250	S	156.250
06	Intership Safety	156.300	S	156.300
07A	Commercial, Intership	156.350	S	156.350
08	Commercial, Intership	156.400	S	156.400
09	Com'l/Non-Commercial	156.450	S	156.450
10	Commercial, Intership	156.500	S	156.500
11	Commercial, Intership	156.550	S	156.550
12	Port Operations	156.600	S	156.600
13**	Bridge to Bridge, 1W	156.650	S	156.650
14	Port Operations	156.700	S	156.700
15*	Environmental(Rec. only)	-----	S	156.750
16	Distress, Safety & Calling	156.800	S	156.800
17*	Maritime Control, 1 W	156.850	S	156.850
18A	Commercial, Intership	156.900	S	156.900
19A	Commercial, Intership	156.950	S	156.950
20A	Port Operations	157.000	S	157.000
21A	U.S. Government Only	157.050	S	157.050
22A	Liaison USCG Only	157.100	S	157.100
23A	Port Operations, Gov't only	157.150	S	157.150
24	Public Correspondence	157.200	D	161.800
25	Public Correspondence	157.250	D	161.850
26	Public Correspondence	157.300	D	161.900
27	Public Correspondence	157.350	D	161.950
28	Public Correspondence	157.400	D	162.000
60	Public Correspondence	156.025	S	156.025
61A	Public Correspondence	156.075	S	156.075
62A	Public Correspondence	156.125	S	156.125

CHANNEL		TRANSMIT	MODE	RECEIVE
63A	Com'l, Port Operations	156.175	S	156.175
64A	Public Correspondence	156.225	S	156.225
65A	Port Operations	156.275	S	156.275
66A	Port Operations	156.325	S	156.325
67**	Bridge-to-Bridge, 1W	156.375	S	156.375
68	Non-Commercial	156.425	S	156.425
69	Non-Commercial	156.475	S	156.475
70	Digital Selective Calling	156.525	S	156.525
71	Non-Commercial	156.575	S	156.575
72	Non-Commercial	156.625	S	156.625
73	Port Operations	156.675	S	156.675
74	Port Operations	156.725	S	156.725
75	Guardband (Rec. only)	-----	S	156.775
76	Guardband (Rec. only)	-----	S	156.825
77	Intership, Port Operations	156.875	S	156.875
78A	Non-Commercial	156.925	S	156.925
79A	Commercial, Intership	156.975	S	156.975
80A	Commercial, Intership	157.025	S	157.025
81A	U.S. Government Only	157.075	S	157.075
82A	U.S. Government Only	157.125	S	157.125
83A	U.S. Government Only	157.175	S	157.175
84	Public Correspondence	157.225	D	161.825
85	Public Correspondence	157.275	D	161.875
86	Public Correspondence	157.325	D	161.925
87	Public Correspondence	157.375	D	161.975
88A	Commercial, Intership	157.425	S	157.425

* = 1 Watt

** = 1 Watt initially, HI/LO must be held for 25 Watt.

APPENDIX B - VHF MARINE WEATHER CHANNEL ASSIGNMENTS

CHANNEL		RECEIVE
WX1	Weather (Receive only) - NOAA	162.550
WX2	Weather (Receive only) - NOAA	162.400
WX3	Weather (Receive only) - NOAA	162.475
WX4	Weather (Receive only) - CANADA	162.425
WX5	Weather (Receive only)	162.450
WX6	Weather (Receive only)	162.500
WX7	Weather (Receive only) - CANADA	162.525
WX8	Weather (Receive only) - ENVIRONMENTAL	161.650
WX9	Weather (Receive only)	161.775
WX10	Weather (Receive only)	163.275

APPENDIX C - INTERNATIONAL VHF MARINE CHANNEL

CHANNEL		TRANSMIT	MODE	RECEIVE
01	Public Corresp., Port Ops	156.050	D	160.650
02	Public Corresp., Port Ops	156.100	D	160.700
03	Public Corresp., Port Ops	156.150	D	160.750
04	Public Corresp., Port Ops	156.200	D	160.800
05	Public Corresp., Port Ops	156.250	D	160.850
06	Intership Safety	156.300	S	156.300
07	Public Corresp., Port Ops	156.350	D	160.950
08	Commercial, Intership	156.400	S	156.400
09	Com'l/Non-Com'l	156.450	S	156.450

CHANNEL		TRANSMIT	MODE	RECEIVE
10	Commercial, Intership	156.500	S	156.500
11	Commercial, Intership	156.550	S	156.550
12	Port Operations	156.600	S	156.600
13**	Bridge-to-Bridge, 1 W	156.650	S	156.650
14	Port Operations	156.700	S	156.700
15	Onboard Communications, (Rec. only)	-----	S	156.750
16	Distress, Safety and Calling	156.800	S	156.800
17*	Maritime Control, 1 W	156.850	S	156.850
18	Port Operations	156.900	D	161.500
19	Commercial, Intership	156.950	D	161.550
20	Public Correspondence	157.000	D	161.600
21	Public Correspondence	157.050	D	161.650
22	Public Correspondence	157.100	D	161.700
23	Public Correspondence	157.150	D	161.750
24	Public Correspondence	157.200	D	161.800
25	Public Correspondence	157.250	D	161.850
26	Public Correspondence	157.300	D	161.900
27	Public Correspondence	157.350	D	161.950
28	Public Correspondence	157.400	D	162.000
60	Public Corresp., Port Ops	156.025	D	160.625
61	Public Corresp., Port Ops	156.075	D	160.675
62	Public Corresp., Port Ops	156.125	D	160.725
63	Public Corresp., Port Ops	156.175	D	160.775
64	Public Corresp., Port Ops	156.225	D	160.825
65	Public Corresp., Port Ops	156.275	D	160.875
66	Public Corresp., Port Ops	156.325	D	160.925
67**	Bridge-To-Bridge, 1 W	156.375	S	156.375
68	Non-Commercial	156.425	S	156.425
69	Non-Commercial	156.475	S	156.475
70	Digital Selective Calling	156.525	S	156.525
71	Port Operations	156.575	S	156.575
72	Non-Commercial	156.625	S	156.625
73	Port Operations	156.675	S	156.675
74	Port Operations	156.725	S	156.725
75	Guardband (Rec. only)	-----	S	156.775
76	Guardband (Rec. only)	-----	S	156.825
77	Intership, Port Operations	156.875	S	156.875
78	Public Corresp., Port Ops,	156.925	D	161.525
79	Public Corresp., Port Ops,	156.975	D	161.575
80	Public Corresp., Port Ops,	157.025	D	161.625
81	Public Corresp., Port Ops,	157.075	D	161.675
82	Public Corresp., Port Ops,	157.125	D	161.725
83	Public Corresp., Port Ops,	157.175	S	161.775
84	Public Correspondence	157.225	D	161.825
85	Public Correspondence	157.275	D	161.875
86	Public Correspondence	157.325	D	161.925
87	Public Correspondence	157.375	D	161.975
88	Public Corresp., Port Ops,	157.425	D	162.025

* = 1 Watt

** = 1 Watt initially, HI/LO must be held for 25 Watts

APPENDIX D - CANADIAN VHF MARINE CHANNEL ASSIGNMENTS (INFOMATION ONLY)

CHANNEL		TRANSMIT	MODE	RECEIVE
01+	Public Correspondence	156.050	D	160.650
02+	Public Correspondence	156.100	D	160.700

CHANNEL		TRANSMIT	MODE	RECEIVE
03+	Public Correspondence	156.150	D	160.750
04	Intership	156.200	S	156.200
05	Public Correspondence	156.250	S	156.250
06	Intership, Safety	156.300	S	156.300
07+*	Commercial, Intership	156.350	S	156.350
08+*	Commercial, Intership	156.400	S	156.400
09*	Commercial, Intership	156.450	S	156.450
10	Commercial, Intership	156.500	S	156.500
11+*	Commercial, Intership	156.550	S	156.550
12+*	Port Operations	156.600	S	156.600
13	Bridge-To-Bridge, I W	156.650	S	156.650
14+**	Port Operations	156.700	S	156.700
15	On Board Communications (Rec. only)	-----	S	156.750
16	Distress, Safety & Calling	156.800	S	156.800
17	Maritime Control	156.850	S	156.850
18+*	Commercial, Intership	156.900	S	156.900
19	Commercial, Intership	156.950	S	156.950
20	Port Operations	157.000	D	161.600
21	Coast Guard	157.050	S	157.050
22+*	Coast Guard	157.100	S	157.100
23+	Public Correspondence	157.150	D	161.750
24+*	Public Correspondence	157.200	D	161.800
25+ -	Public Correspondence	157.250	D	161.850
26	Public Correspondence	157.300	D	161.900
27+*	Public Correspondence	157.350	D	161.950
28+	Public Correspondence	157.400	D	162.000
60+	Public Correspondence	156.025	D	160.625
61^	Coast Guard	156.075	S	156.075
62^	Coast Guard	156.125	S	156.125
63	Ship-to-Ship	156.175	S	156.175
64^+	Public Correspondence	156.225	S	156.225
65**	Port Operations	156.275	S	156.275
66**	Port Operations	156.325	S	156.325
67+*	Commercial, Intership	156.375	S	156.375
68+*	Non-Commercial	156.425	S	156.425
69+*	Non-Commercial	156.475	S	156.475
70+*	Non-Commercial	156.525	S	156.525
71+*	Non-Commercial	156.575	S	156.575
72+	Non-Commercial	156.625	S	156.625
73+*	Port Operations	156.675	S	156.675
74+*	Port Operations	156.725	S	156.725
77**	Commercial, Intership	156.875	S	156.875
78	Non-Commercial	156.925	S	156.925
79+*	Commercial, Intership	156.975	S	156.975
80+*	Commercial, Intership	157.025	S	157.025
81*	Coast Guard	157.075	S	157.075
82*	Coast Guard	157.125	S	157.125
83+*	Coast Guard, Auxiliary	157.175	S	157.175
84+	Public Correspondence	157.225	D	161.825
85+	Public Correspondence	157.275	D	161.875
86+	Public Correspondence	157.325	D	161.925
87+	Public Correspondence	157.375	D	161.975
88+*	Commercial, Intership	157.425	D	162.025

^ = Atlantic Coast only

+ = Pacific Coast only

* = St. Lawrence River area only

** = St. Lawrence River area 1 WATT MAXIMUM

APPENDIX E - PHONETIC ALPHABET AND GLOSSARY

The following list consist of the standard phonetic alphabet, normally used to clarify the transmission of a series of letters.

A - Alpha	J - Juliette	S - Sierra
B - Bravo	K - Kilo	T - Tango
C - Charlie	L - Lima	U - Uniform
D - Delta	M - Mike	V - Victor
E - Echo	N - November	W- Whiskey
F - Foxtrot	O - Oscar	X - X Ray
G - Golf	P - Pappa	Y - Yankee
H - Hotel	Q - Quebec	Z - Zulu
I - India	R - Romeo	

AFFIRMATIVE, used as an answer indicating "yes".

ANTENNA, any part of a radio transmitter that radiates radio energy.

BREAK, used to separate the text from other parts of a message or to separate one message from another.

CHANNEL, a particular frequency or pair of frequencies.

COAX, an electrical conductor used to carry radio energy from the transmitter to the antenna. Normally, the coax has an inner conductor insulated from the outer braided wire shield.

I SPELL, indicates the operator is going to spell the following word, usually using the phonetic alphabet.

MAYDAY, the English of the French M'aidez, "Help Me!"

NEGATIVE, used to indicate an answer of "no". Simply answering yes or no is easily misunderstood when a transmission is weak or noisy.

OUT, signals that the transmission has ended and no reply is expected.

OVER, ends a message and indicates a reply is expected.

ROGER, signals that the message was received satisfactorily.

STANDBY, simply means to wait.

WILCO, this message is a reply that indicates the previous message was received, understood and will be carried out.

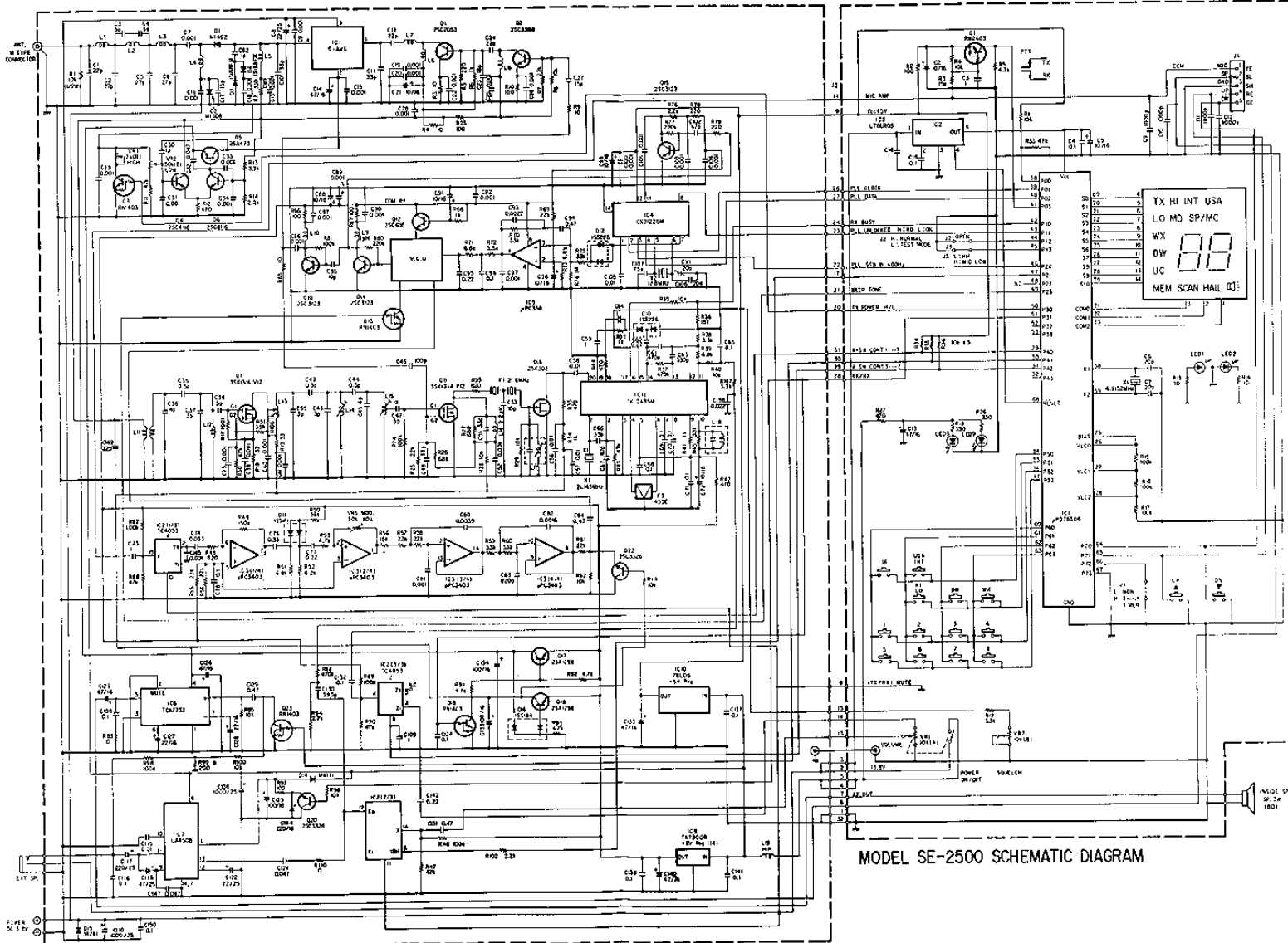

MODEL SE-2500 SCHEMATIC DIAGRAM

SHAKESPEARE LIMITED WARRANTY

Shakespeare Company, Inc. (Shakespeare) warrants your VHF radiotelephone or related accessory for two years from date of original purchase against manufacturing defects in material and workmanship in accordance with the following terms and conditions. This warranty applies to the original purchaser only and is not transferable.

During the warranty period, Shakespeare will repair or replace without charge valid defects in material and workmanship. Warranty does not apply to products that have been damaged through accident, misuse, negligence, modification, alteration, abuse, or normal expected wear. Damage that is determined to be of this nature will be repaired at the consumer's expense.

Products which have had the serial number modified, defaced or removed will not be eligible for repair under this limited warranty.

Shakespeare will not be liable for damages consequential and otherwise arising from the use or inability to use this product. Shakespeare's liability is limited to the repair or replacement of the equipment during the warranty period.

Repairs or adjustments covered under this warranty are to be determined by Shakespeare.

We require proof of original purchase date for warranty determination. A copy of the sales invoice or canceled check is satisfactory evidence. This procedure insures that you receive full-term warranty from the date of original purchase so that the time the unit remains in dealer stock is not deducted.

After the first 30 days following the original date of purchase, all shipping charges to return units for repair are the responsibility of the customer. Please pack the unit carefully to eliminate shipping damage. It is wise to insure shipments against loss or damage. Return the unit to Shakespeare Company, Electronics and Fiberglass Division, RFD 3, P.O. Box 733, Newberry, SC 29108, Attention: Warranty Repair Department. Please include a detailed description of the problem you are experiencing along with proof of purchase. Shakespeare will return the repaired unit to you prepaid. Inquiries concerning the status of a warranty claim may be sent to the address above or expedited by telephoning (803) 276-5504 and asking for the Warranty Service Department.

This warranty gives you specific legal rights, and you may also have other rights which vary from state to state.

Prior to returning a unit, we encourage you to contact the Shakespeare Consumer Service Department by telephone or letter to discuss the nature of the problem. Many times a satisfactory solution can be reached without the need of returning the item.

The Consumer Service Department is also available for out of warranty service and to assist you with any questions or problems associated with the Shakespeare product you purchased.

WARRANTY AND POLICY ARE SUBJECT TO CHANGE WITHOUT PRIOR NOTICE

SHAKESPEARE COMPANY
Electronics and Fiberglass Division
RFD 3 P.O. Box 733
Newberry, SC 29108
Phone 803-276-5504 Fax 803-276-8940

Shakespeare[®]

A an Anthony Industries company

MARINE VHF TRANSCEIVER EMERGENCY OPERATION PROCEDURE

1. Select Channel 16.
2. Press microphone button.
3. Say, "**MAYDAY-MAYDAY-MAYDAY. THIS IS (vessel name), (vessel name), (vessel name), (call letters), MAYDAY.**"
4. Tell where you are. (Be as precise as possible.)
5. State the nature of your distress.
6. Give number of adults and children on board and describe any injuries.
7. Estimate the seaworthiness of your vessel.
8. Briefly describe your vessel.
9. Say, "**I WILL BE LISTENING ON CHANNEL 16.**"
10. End with, "**THIS IS (VESSEL NAME & CALL SIGN), OVER.**"
11. Release the microphone button and listen for a reply. If no reply, repeat distress call. If there is still no answer, switch to another channel and repeat the distress call.



Shakespeare[®]



an Anthony Industries company

SHAKESPEARE COMPANY
Electronics and Fiberglass Division
RFD 3 P.O. Box 733
Newberry, SC 29108
Phone 803-276-5504 Fax 803-276-8940

Shakespeare[®]

SINCE 1897

ELECTRONICS & FIBERGLASS DIVISION

A an Anthony Industries company

SHAKESPEARE VHF MODEL SE 2550 OR SE 2500 REVERSE PANEL GASKET INSTALLATION PROCEDURE

To reverse the front panel of your Model SE 2550 or SE 2500 Marine VHF Radio for Overhead or Bulkhead mounting, a special Reverse Panel Gasket is provided to you from Shakespeare. Please call the toll free number below for the required gasket:

1-800-845-7750 (EXT 320)

When you have received this gasket, follow the instructions below and study the guidelines in your Owner's Manual in Section 2.4 page #8, for proper installation. It is important to assure you have a proper watertight fit.

1. Disconnect all connections from the back of the radio and remove the four screws on the back of the unit securing the plastic cover case to the metal chassis.

2. Slide the cover case off the radio and remove the existing front panel gasket. DO NOT turn or touch any of the radio internal component settings or adjustments. They are factory aligned.

3. Identify the White Dot on the Reverse Panel Gasket you have just received. This White Dot is on the TOP BACK SIDE of the gasket and will face the top rear of the radio when installed properly. The side of the gasket with the female slotted groove goes entirely around the plastic front display panel male lip. Slide the gasket over the chassis and place around the front display panel accordingly. Check again and be sure the White Dot is on the TOP of the radio nearest the Volume and Squelch Knobs and NOT on the bottom nearest the Keypad area.

4. Rotate the radio's cover case 180 degrees.

5. Tilt the front display panel assembly itself down about 40 degrees. The panel assembly easily rotates in the hinged slots located between the front display panel and the metal chassis of the radio. There is no need to loosen the 4 brass hinge screws.

6. Slide the radio's cover case back on the chassis. DO NOT pinch any radio wiring or cabling and check that the rear chassis sealing gasket remains properly in place.

7. Seat the cover case onto the Reverse Panel Gasket. Re-install the four cover case screws you removed in Step #1. Do not overtighten at this point. Gently lift the edge of the Reverse Panel Gasket all around the cover case with your fingernail to assure a positive fit and no gasket binding. Then, tighten the rear screws snugly. Double check for a smooth, proper fit of the Reverse Panel Gasket all around the radio's case. When properly installed, there should be no bulging or warping of the gasket.

8. Mount the trunion bracket on the top of the radio as shown in Figure 2.2 on page #9 of your Owner's Manual for your vessel's proper Overhead or Bulkhead installation.